



## Features

- Digital
- High Accuracy
- Wide Field of View
- Albedo Detection
- Electronic Shutter

# HSNF-01

## HOJJAT FANAVAR PAJOOH

## Mechanical Interface

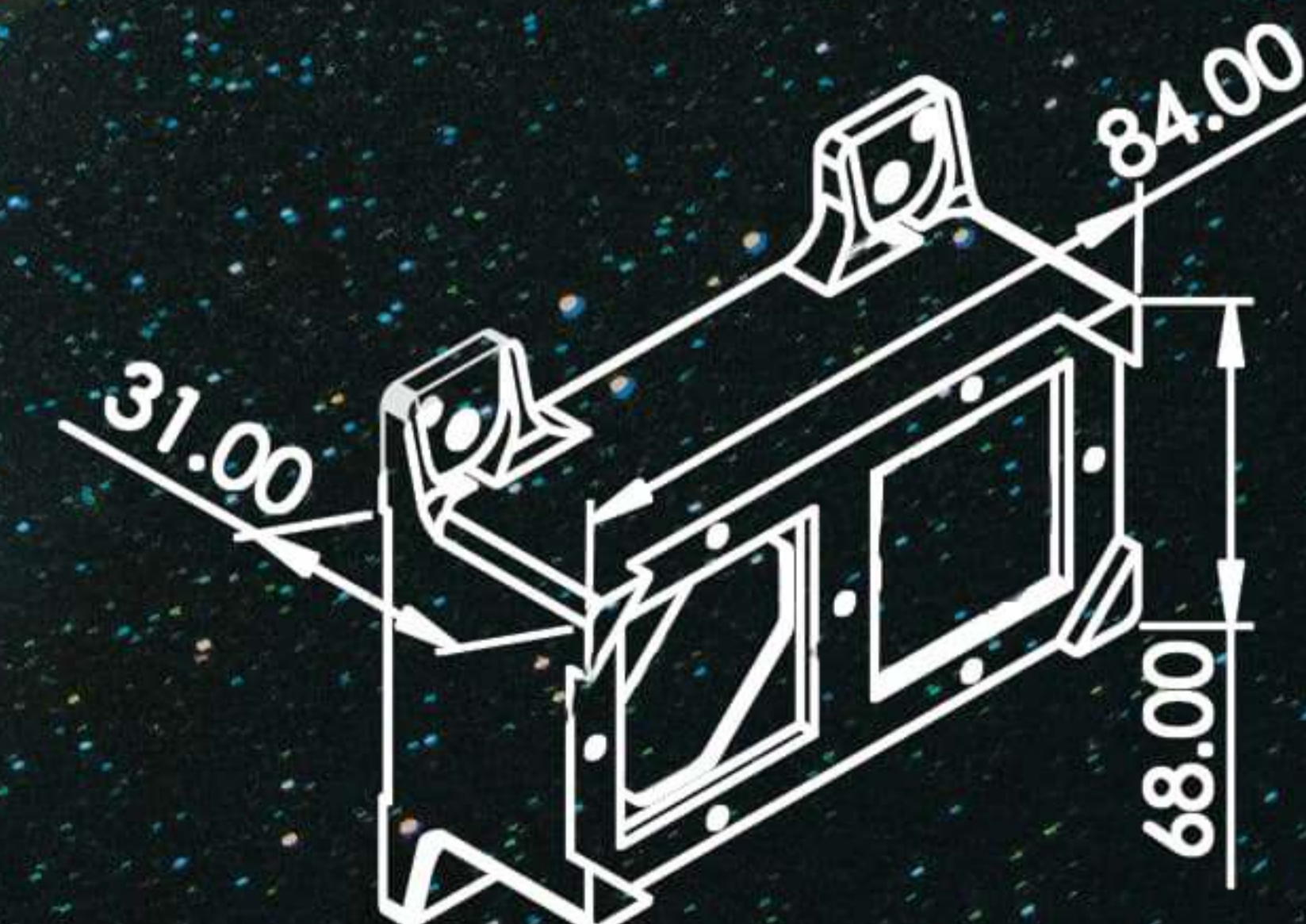
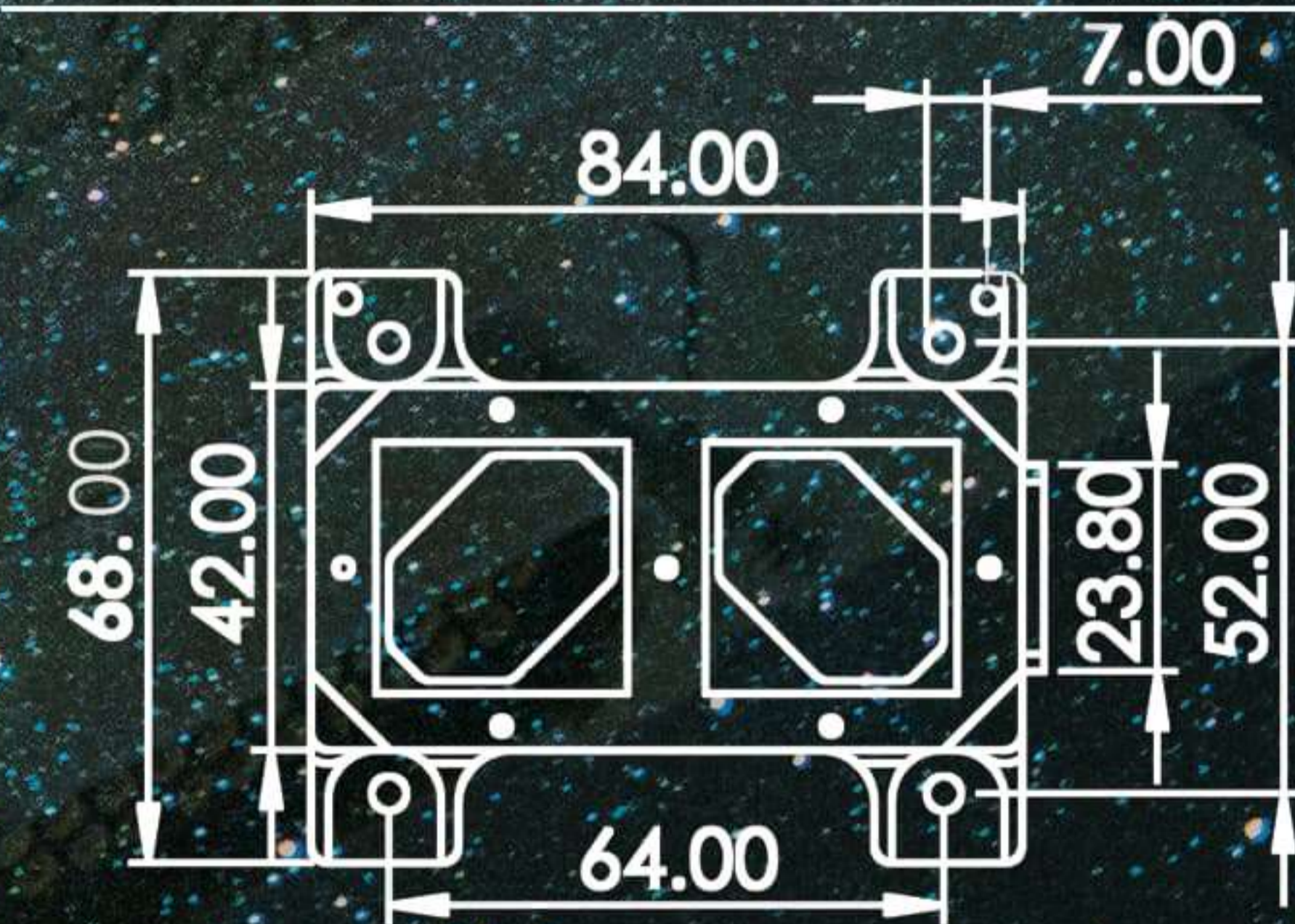

# DIGITAL SUN NORTH FINDER



021-77141624 0910 788 9261

[www.hojjatco.com](http://www.hojjatco.com)

[info@hojjatco.com](mailto:info@hojjatco.com)

# Qualification

The tests have been done on HSS sun sensor are listed below:

Qualification Test	Standard
Mechanical	ECSS-E10-03A ECSS-STD-7000
Thermal	ECSS-E-10-03A
EMC/EMI	MIL-STD-461F
Radiation (TID)	MIL-STD-883G

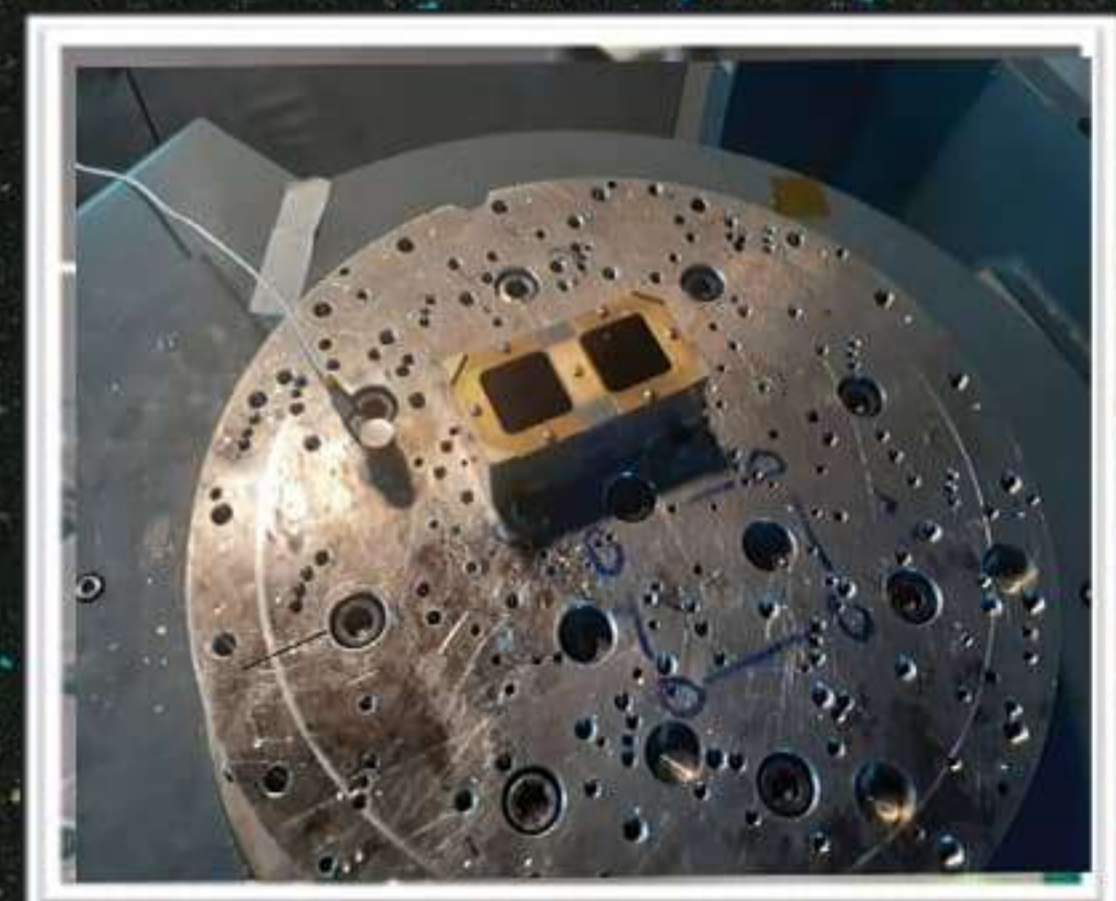

**Mechanical**

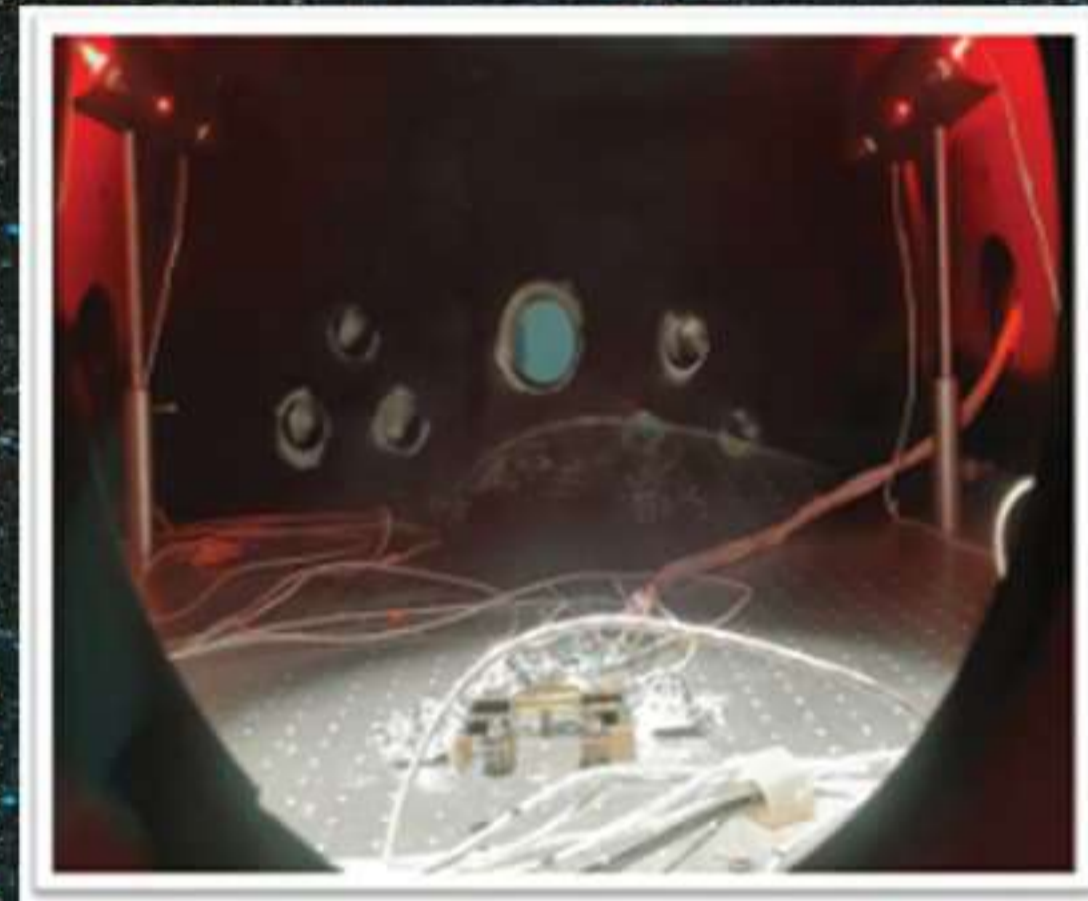

**Thermal**



**EMC/EMI**

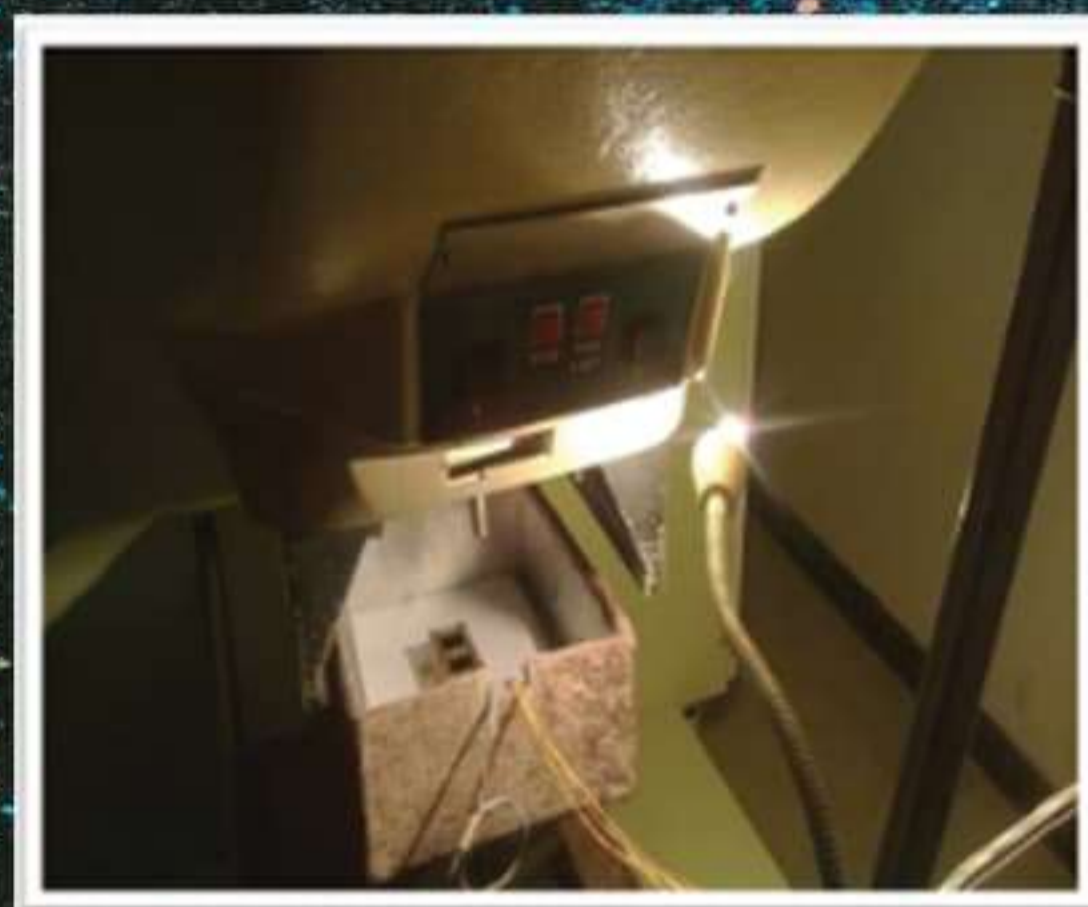

**Radiation**

Based on Several Functional & Environmental Tests on HFP Digital Sun Sensor, This Product used in more than 10 missions.

# Technical Characteristics

Parameter	Value
<b>Functional Properties</b>	
Accuracy ( $3\sigma$ )	< 0.5
Filed-Of-View	$\pm 65^\circ$
Update Rate	Up to 10 Hz
Output	Digital Vector
Data Interface	RS485 Full Duplex and CAN
<b>Environmental Properties</b>	
Temperature	-25° to +65°C
Vibration	15g RMS
Electrical	MIL-STD 461F
Radiation	15 kRad (component level)
<b>Electrical Properties</b>	
Power Supply	5 Volt $\pm$ 5%
Current Consumption	< 80 mA
<b>Physical Properties</b>	
Dimension	84 * 68 * 31 mm <sup>3</sup>
Mass	150 gr
Connector	Micro-D

# Utility

The sun sensor determines the direction of the sun position vector on its own matched coordinate system. The extracted information from sun location by sun sensor can be used for locating the satellite Attitude control process.

Variety of sun sensors from very high to normal accuracies with different power consumption and dimensions, caused them to be considered for a wide range of space applications. In conclusion, they became an inseparable part in satellite ADCS process. Hojjat Fanavar Pajouh company, has designed and manufactured various type of sun sensors that HSS-01 is one of them. This sensor is digital and two axis. HSS-01 is a fine sun sensor, for this reason, as well as other physical properties, HSS-01 can be one of the best choices for ADCS solution.

